

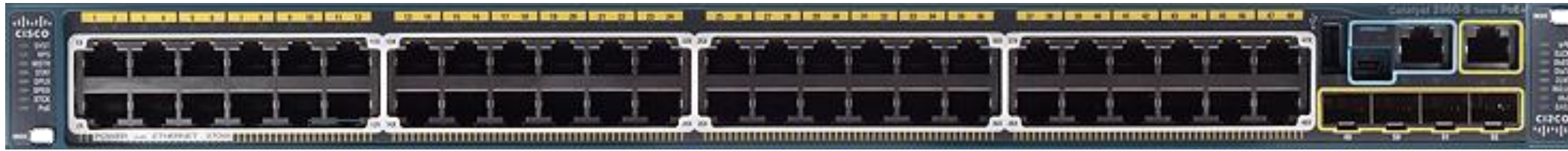

**HCCS ALIEF FILMAKING FACILITIES
 SOUND STAGE & STUDIOS
 VIDEO CONTROL
 ENGINEERING CORE
 SYSTEMS SUMMARY**

- VIDEO CONTROL ROOM FLOORPLAN
- NETWORK LAN
- VIDEO CONTROL ROOM – INTERCOM
- VIDEO CAMERAS – INTERCOM
- VIDEO CAMERA - CONFIGURATION
- VIDEO CONTROL ROOM – ENGINEERING RACKS
- ENGINEERING AUDIO MONITORS
- VIDEO CONTROL OPEN GEAR FRAME
- OPEN GEAR ANALOG/DIGITAL PROCESSING
- OPEN GEAR FRAME – REAR PLATES
- BLACK MAGIC MULTIVIEWER 16 ONE
- BLACK MAGIC MULTIVIEWER 16 TWO
- BLACK MAGIC MULTIVIEWER LOOP THRU
- VIDEO CONTROL REFERENCE BLACK SIGNAL
- VIDEO CONTROL VIDEO PATCH PANEL MATRIX
- VIDEO CONTROL VIDEO PATCH PANELS VPP1-3
- VIDEO CONTROL VIDEO PATCH PANELS VPP4-6
- VIDEO CONTROL MASTER CLOCK SYSTEM
- VIDEO CONTROL RECORD & PLAYBACK
- VIDEO CONTROL LEADER TEST & MONITOR
- VIDEO CONTROL POWER CONSUMPTION

 HCC TV <small>HOUSTON COMMUNITY COLLEGE</small>	<i>2016 HCCS ALIEF FILMAKING</i>		
	<i>DIRECTORY</i>		
L. BLANE HUHN	DATE JAN 13, 2016	DWG NO FILM – 2016 – 01	REV
HCC TV	SCALE NONE	11"x17"	SHEET 1 OF 27



If you want to choose a different static IP address, you can set it to anything you like that's in the same range as the ATEM switcher, so long as it's not already in use by another device on your network. Default IP addresses for ATEM products are best avoided for this reason, including: 192.168.10.1, 192.168.10.2, 192.168.10.3, 192.168.10.10, 192.168.10.50 and 192.168.10.240.

Apple I-Mac Retina 5K: 4.0GHz
 Quadcore i7; 16GB 1600 MHz
 SDRAM; 1 TB Flash Storage;
 AMD Radeon R9 M295X 4GB
 GDDR5

	2016 HCCS ALIEF FILMAKING		
	APPLE SYSTEM COMPONENTS		
L. BLANE HUHN	DATE FEB 08, 2016	DWG NO FILM - 2016 - 01	REV
HCC TV	SCALE NONE	11"x17"	SHEET 2 OF 27

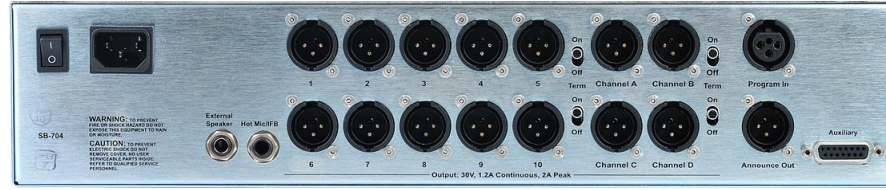

Clear Com Intercom System Detail

1	SB-704 Main Station
8	RM-702 Remote Station
1	IF 4W4 4 Channel Camera Interface
2	KB-702 Wall Station
5	RS-701 Belt Pack: Single Channel
2	FL-7 Call Signal Flasher
2	TR-50 Talent IFB Receiver
2	CC-010 IFB Earset
8	CC-26K Lightweight Headset
5	CC-300 Single Muff Headset
4	CC-400 Double Muff Headset
2	HS-6 Telephone Style Hand Set



2016 HCCS ALIEF FILMAKING

CLEARCOM SYSTEM INTERCONNECT

L. BLANE HUHN

DATE
FEB 08, 2016

DWG NO
FILM - 2016 - 01

REV

HCC TV

SCALE NONE

11"x17"

SHEET 3 OF 27

CAM 1

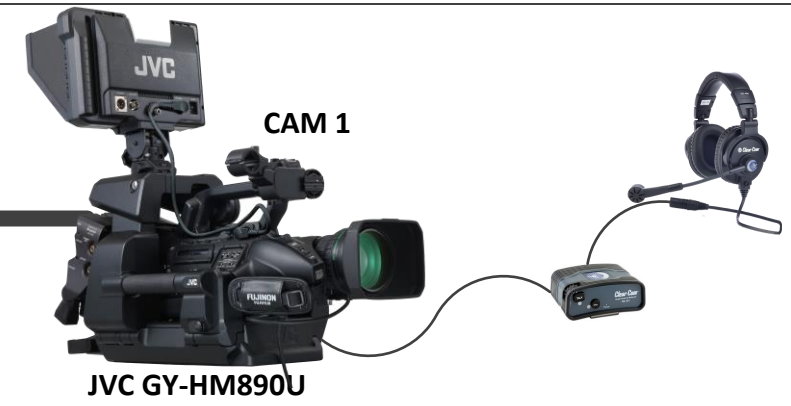

CAM 2



CAM 3



RM-HP790DE : 2-wire system, which uses the [H] and [C] terminals. *1

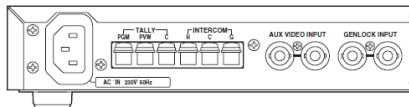

CAM 4 FUTURE

IF4W4

Pin 1 --- Common
Pin 2 --- Power
Pin 3 --- Intercom audio



DYNAMIC MIC HEADSET EMULATION

Figure 2-5 shows the IF4W4 connections to a Clear-Com style headset connector. Pins #1 and #2 are for microphone output. Pins #4 and #5 are for headset emulation.

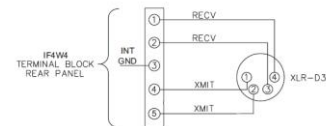

	2016 HCCS ALIEF FILMMAKING		
	CAMERA INTERCOM SYSTEM		
L. BLANE HUHN	DATE APR 25, 2016	DWG NO FILM - 2016 - 01	REV
HCC TV	SCALE NONE	11"x17"	SHEET 4 OF 27

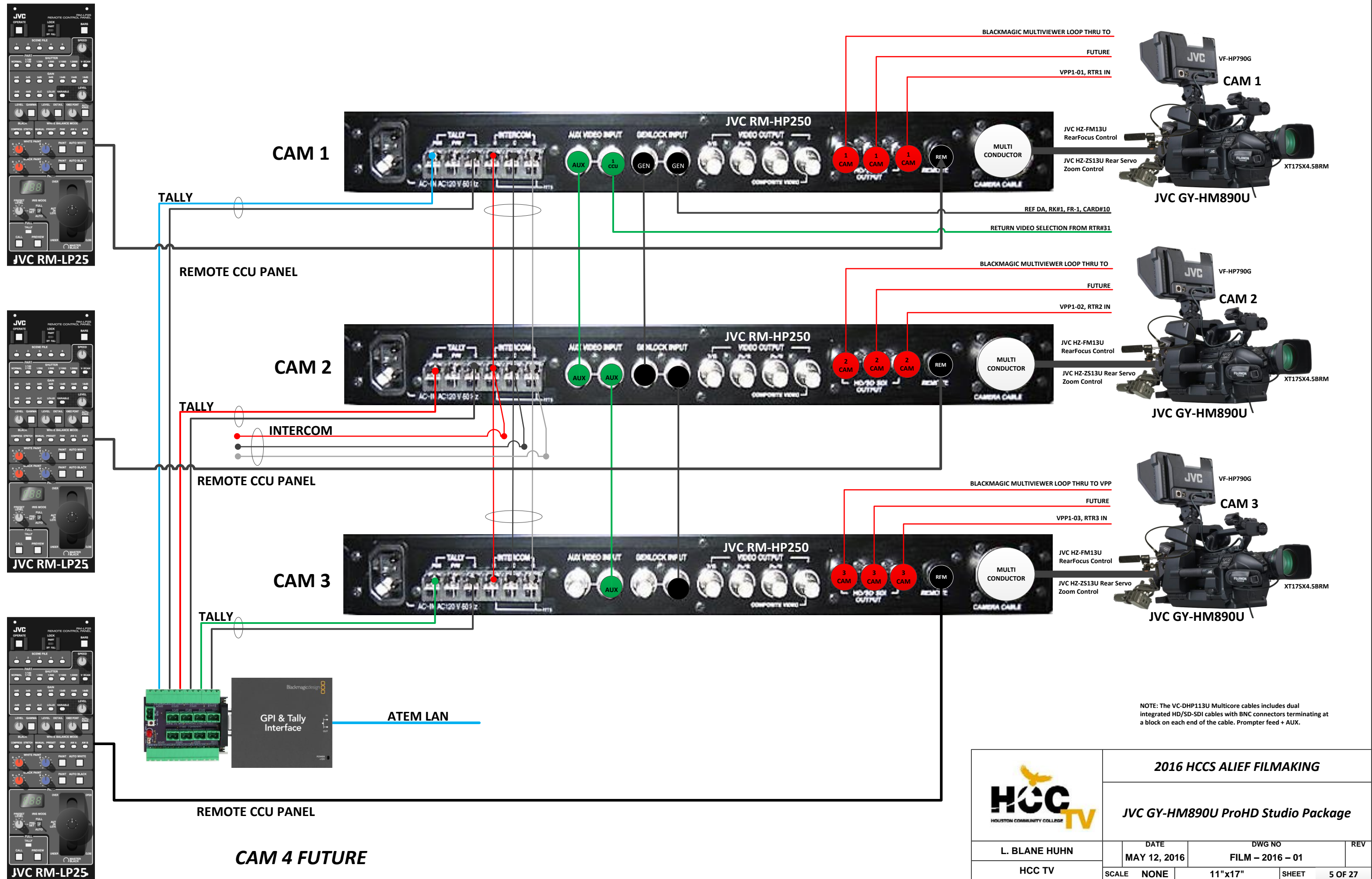

NOTE: The VC-DHP113U Multicore cables includes dual integrated HD/SD-SDI cables with BNC connectors terminating at a block on each end of the cable. Prompter feed + AUX.

	2016 HCCS ALIEF FILMAKING		
	JVC GY-HM890U ProHD Studio Package		
L. BLANE HUHN	DATE MAY 12, 2016	DWG NO FILM - 2016 - 01	REV
HCC TV	SCALE NONE	11"x17"	SHEET 5 OF 27



	2016 HCCS ALIEF FILMAKING			
	VCR ENGINEERING RACK #3			
L. BLANE HUHN	SIZE	DATE	DWG NO	REV
HCC TV		AUG 10, 2016	FILM - 2016 - 01	
	SCALE	NONE	11"x17"	SHEET 6 OF 27



REAR VIEW

	2016 HCCS ALIEF FILMAKING			
	ENGINEERING RACK #3 (rear)			
L. BLANE HUHN	SIZE	DATE AUG 10, 2016	DWG NO FILM - 2016 - 01	REV
HCC TV	SCALE	NONE	11"x17"	SHEET 7 OF 27



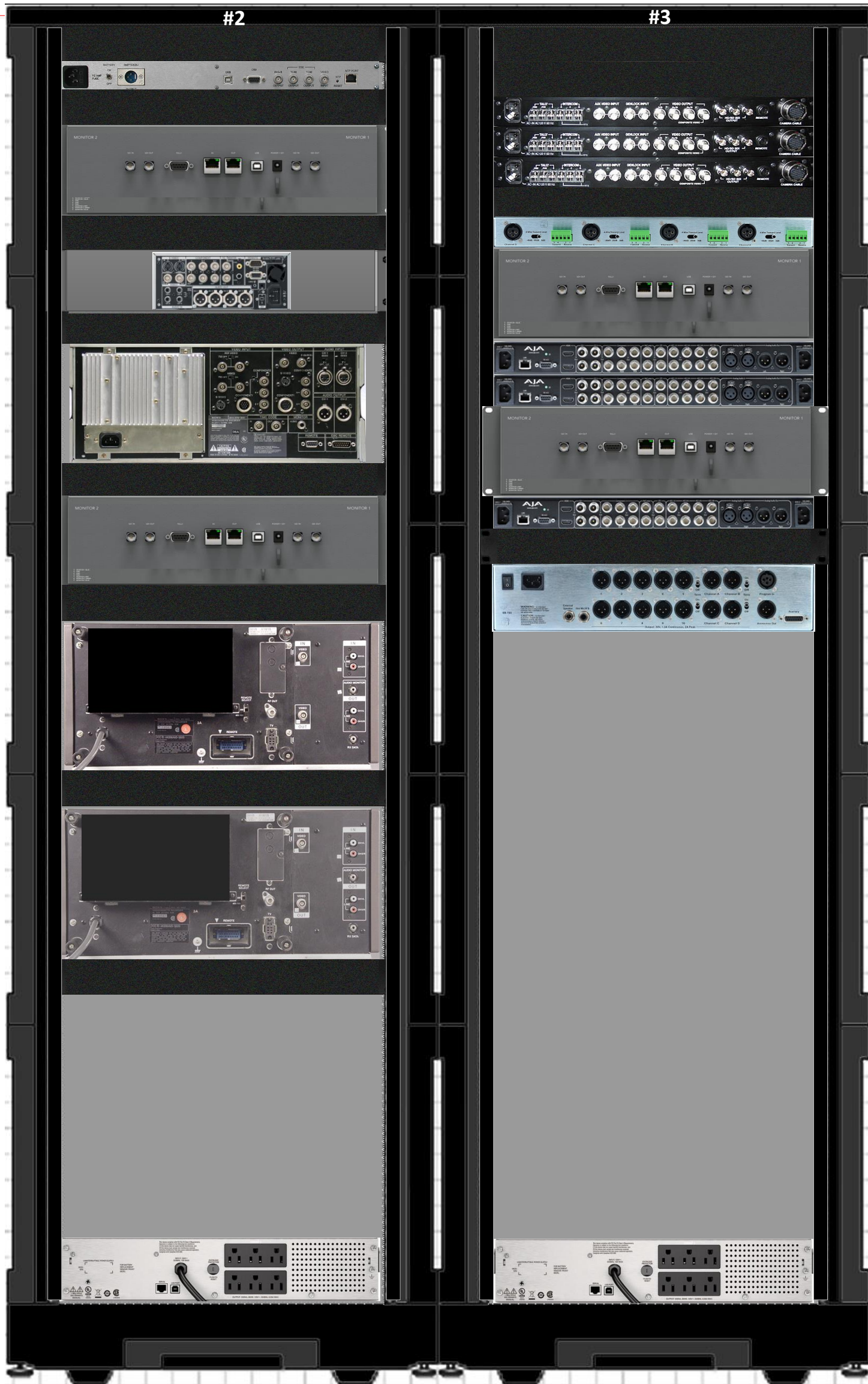

	2016 HCCS ALIEF FILMAKING			
	VCR ENGINEERING RACK ELEVATIONS RACKS# 3 & 2			
L. BLANE HUHN	SIZE	DATE	DWG NO	REV
HCC TV		AUG 10, 2016	FILM - 2016 - 01	
	SCALE	NONE	11"x17"	SHEET 8 OF 27

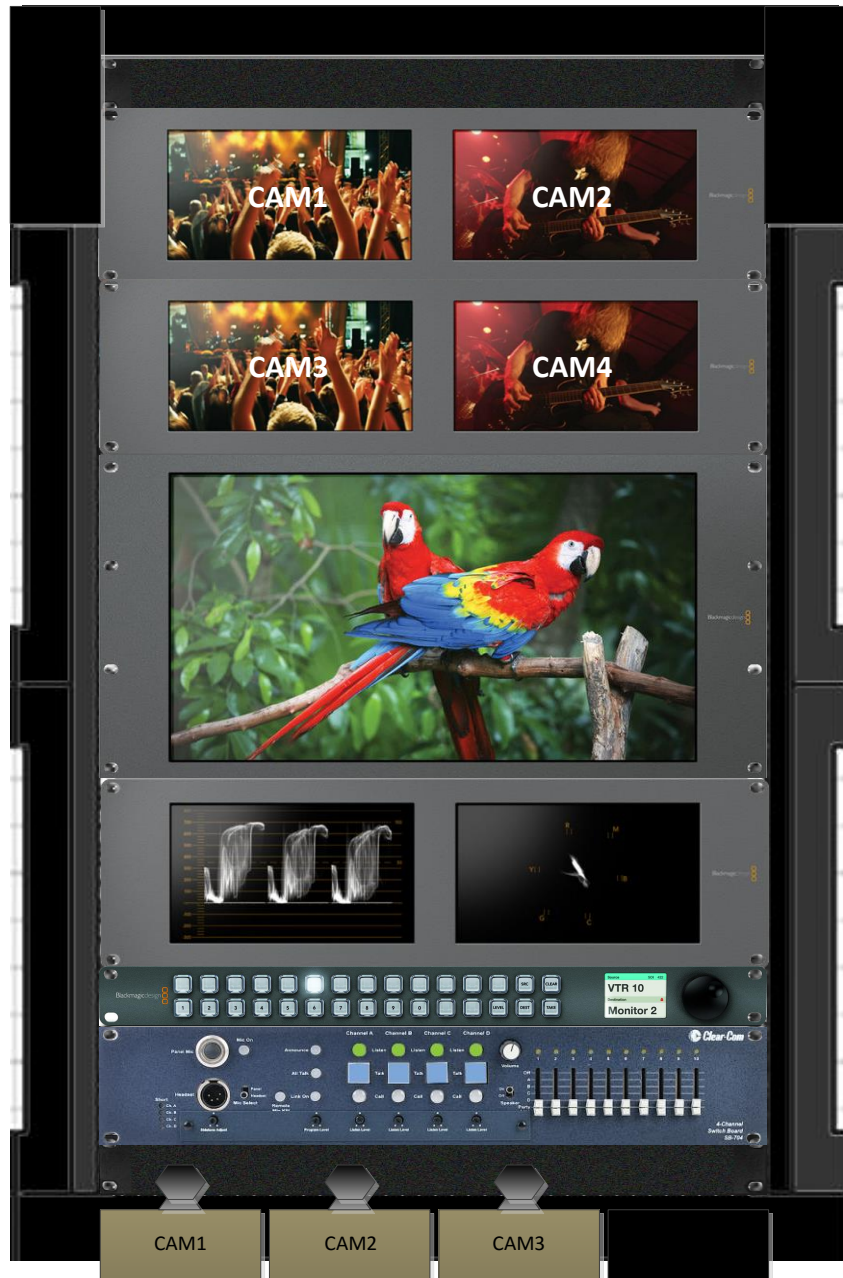

REAR VIEW

	2016 HCCS ALIEF FILMAKING		
	CONTROL ROOM RACK ELEVATIONS RACKS# 3 & 2 (rear)		
L. BLANE HUHN	DATE	DWG NO	REV
	AUG 10, 2016	FILM - 2016 - 04	
HCC TV	SCALE NONE	11"x17"	SHEET 9 OF 27



	2016 HCCS ALIEF FILMMAKING			
	ENGINEERING CAMERA CONTROL STATION 21U DESKTOP RACK			
L. BLANE HUHN	SIZE	DATE AUG 5, 2016	DWG NO FILM - 2016 - 01	REV
HCC TV	SCALE	NONE	11"x17"	SHEET 10 OF 27

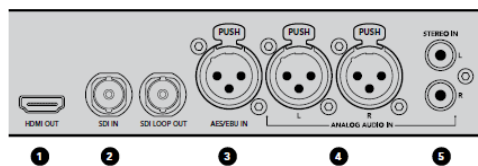
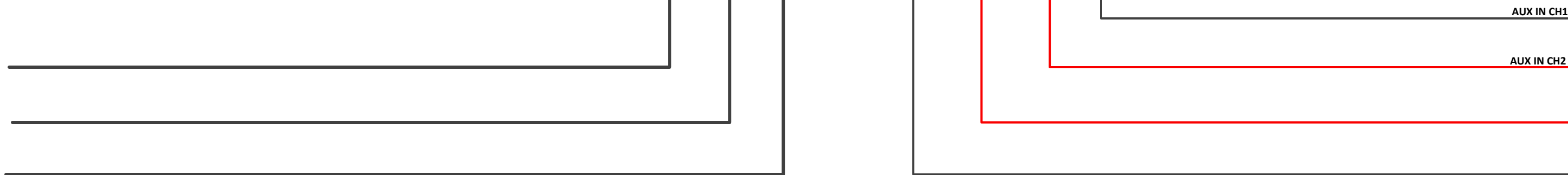
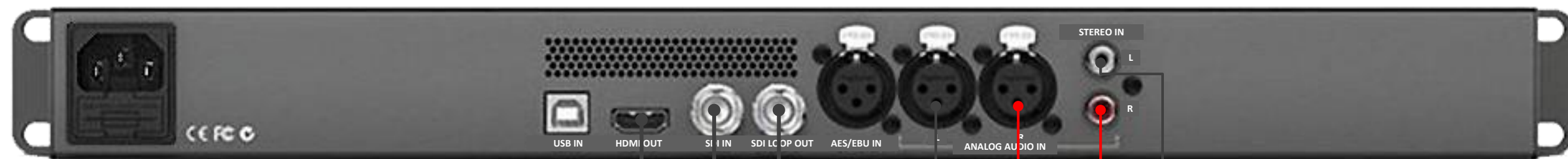
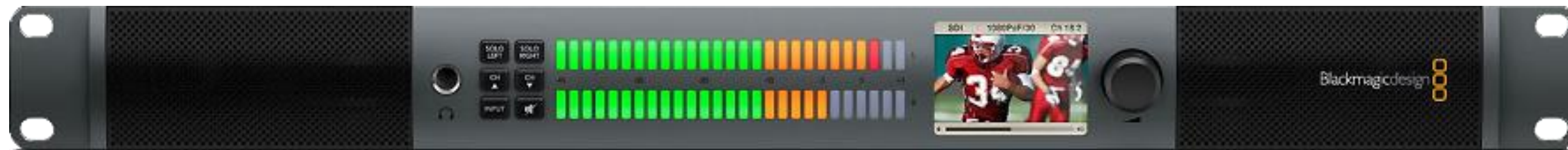

- 1. HDMI
- 2. SDI embedded audio
- 3. XLR for AES/EBU
- 4. XLR for Analog audio
- 5. RCA for consumer audio connections

	2016 HCCS ALIEF FILMAKING		
	BLACK MAGIC ATEM SWITCHER SYSTEM		
L. BLANE HUHN	DATE FEB 08, 2016	DWG NO FILM - 2016 - 01	REV
HCC TV	SCALE NONE	11"x17"	SHEET 11 OF 27

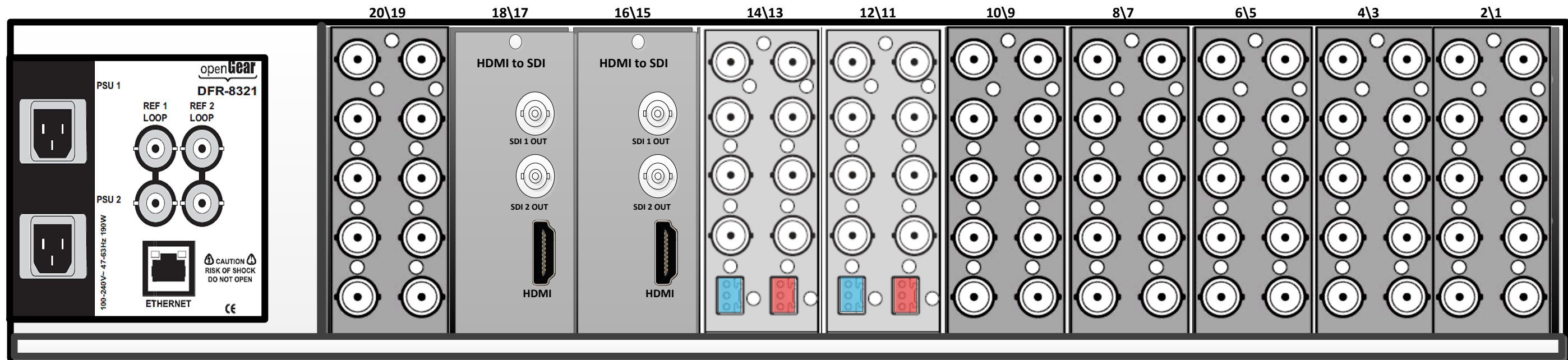

RACK #	FRAME #	MODEL	SLOT	CARD	FUNCTION	SIGNAL	PORT 1	PORT 2	PORT 3	PORT 4	PORT 5	PORT 6	PORT 7	PORT 8
1	FR-01	OG3-FR	1/2	CONVOPENGSDIDA	VIDEO DA	GRFX1 PGM		MV1-05						
			3/4	CONVOPENGSDIDA	VIDEO DA	GRFX1 KEY		MV1-06						
			5/6	CONVOPENGSDIDA	VIDEO DA	GRFX2 PGM		MV1-07						
			7/8	CONVOPENGSDIDA	VIDEO DA	GRFX2 KEY		MV1-08						
			9/10	CONVOPENGSDIDA	VIDEO DA	PROGRAM	STUDIO	STUDIO	12XHUB					
			11/12	CONVOPENGASA	HSDI to ANALOG	ROUTED								
			13/14	CONVOPENGAAS	ANALOG to HSDI	ROUTED								
			15/16	CONVOPENGBHS	HDMI to HSDI	PATCH PLATE								
			17/18	CONVOPENGBHS	HDMI to HSDI	PATCH PLATE								
			19/20	CONVOPENGSYNC	TRI LVL SYNC GEN	REF BLK	SWR1	CAM(L)	AJA(L)	ULTRA 1	ULTRA 2			SWR2
				SPARE	CONVOPENGSDIDA									

GRFX1 PGM/MV1-05 & GRFX1 KEY/MV1-06 via VDA1 and VDA2
 GRFX2 PGM/MV1-07 & GRFX2 KEY/MV1-08 via VDA3 and VDA4
 TSG/BARS NOT INCLUDED
 FRAME SYNCH NOT INCLUDED

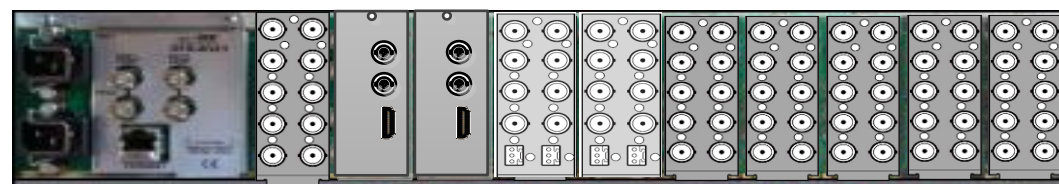

OPEN GEAR FRAME

- 1 Blackmagic Open Frame Video Processor Rack
- 1 Blackmagic Openframe Sync Generator: Tri-level
- 6 Blackmagic Open Frame Distribution Amp
- 2 Blackmagic Open Frame HDMI to HD-SDI Converter
- NOTE - The following cards are not totally routable:
 - 1 Blackmagic Open Frame Analog to HD-SDI Converter
 - > requires discrete analog input audio patch
 - 1 Blackmagic Open Frame HD-SDI to Analog Converter
 - > requires discrete analog output audio patch
- One of DA's may be reallocated for LEADER TSG; TBD

	2016 HCCS ALIEF FILMAKING		
	BLACK MAGIC OPEN GEAR FRAME		
L. BLANE HUHN	DATE APR 07, 2016	DWG NO FILM - 2016 - 01	REV
HCC TV	SCALE NONE	11"x17"	SHEET 12 OF 27

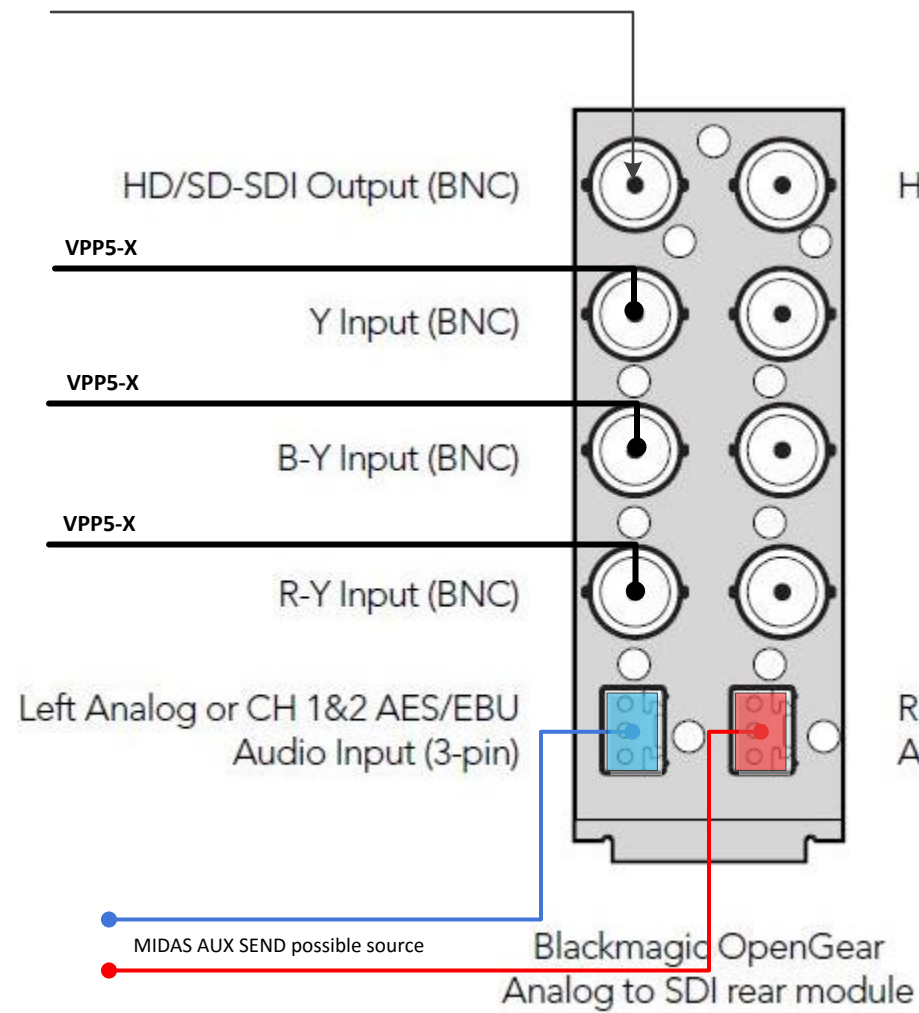

NOTE - These two cards are not totally rout
 1 Blackmagic Open Frame Analog to HD-SD
 > requires discrete analog input audio
 1 Blackmagic Open Frame HD-SDI to Analog
 > requires discrete analog output audi

CONSIDER:
 XLR/BNC 1RU RACK PLATE FOR ANALOG/HDSDI
 ROUTED HDSDI to ANALOG XCONV SHOULD FEE
 MIDAS-IP INPUT/AUX IN

Analog to SDI Conversion
 This module is designed to convert analog HD/SD component, NTSC, PAL or S-video input to SDI output with balanced AES/EBU and analog audio embedding. It is well suited for use with Betacam SP, VHS, set-top boxes, gaming consoles, and HDV cameras, among other possible equipment and applications.

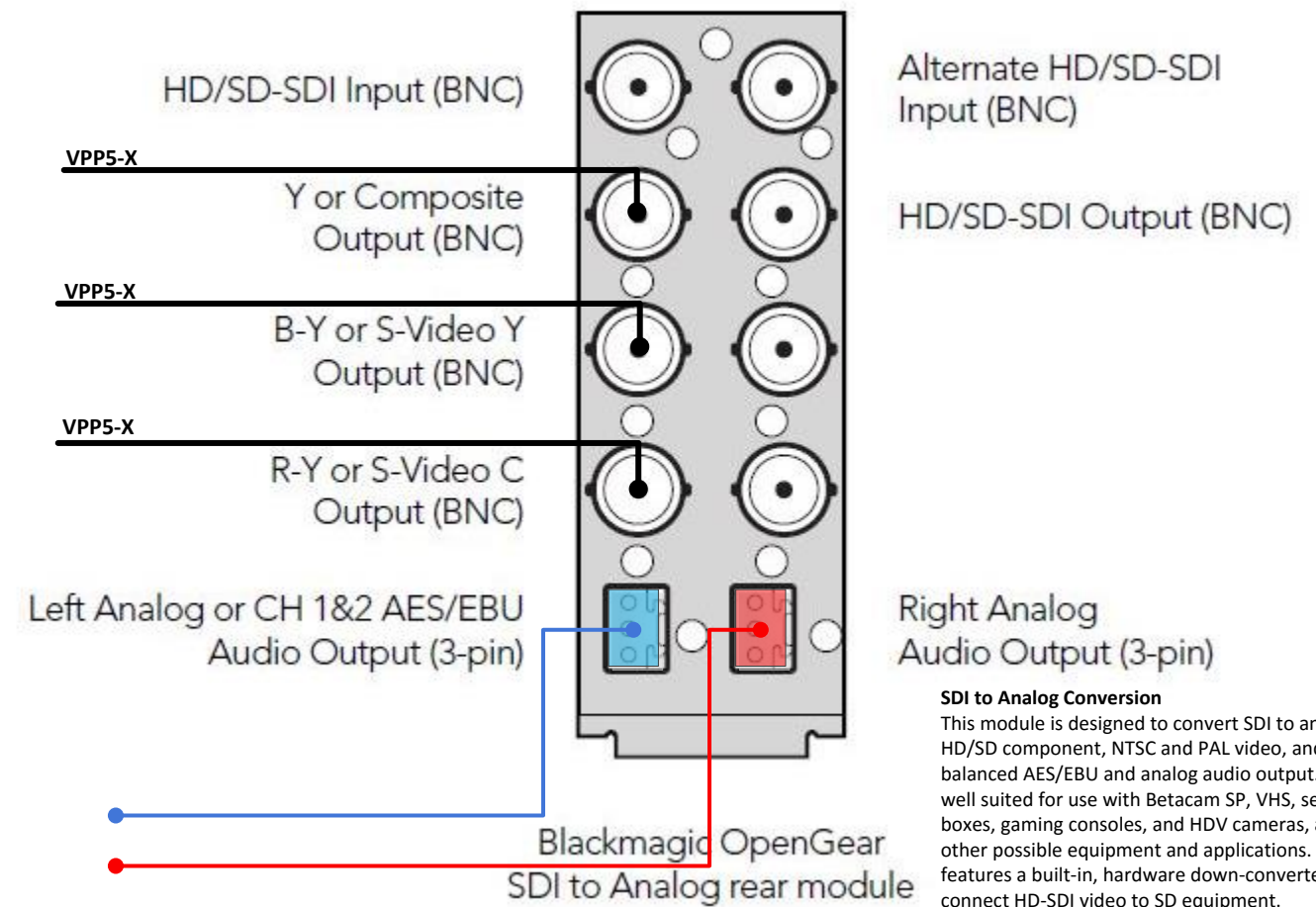

SDI to Analog Conversion
 This module is designed to convert SDI to analog HD/SD component, NTSC and PAL video, and balanced AES/EBU and analog audio output. It is well suited for use with Betacam SP, VHS, set-top boxes, gaming consoles, and HDV cameras, among other possible equipment and applications. It also features a built-in, hardware down-converter to connect HD-SDI video to SD equipment.

	2016 HCCS ALIEF FILMAKING		
	ANALOG / SDI CROSS CONVERTORS (OPEN GEAR FRAME)		
L. BLANE HUHN	DATE MAY 17, 2016	DWG NO FILM - 2016 - 01	REV
HCC TV	SCALE NONE	11"x17"	SHEET 13 OF 27

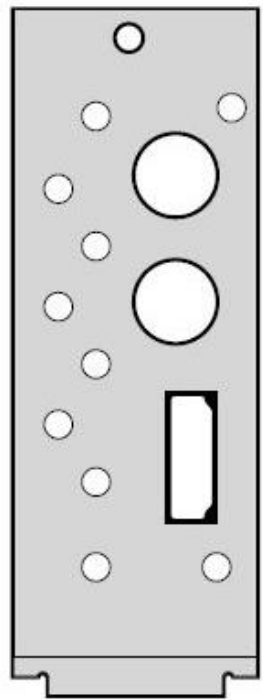

HD/SD-SDI Output
 HD/SD-SDI Output
 HDMI Input

Blackmagic OpenGear
 HDMI to SDI rear module

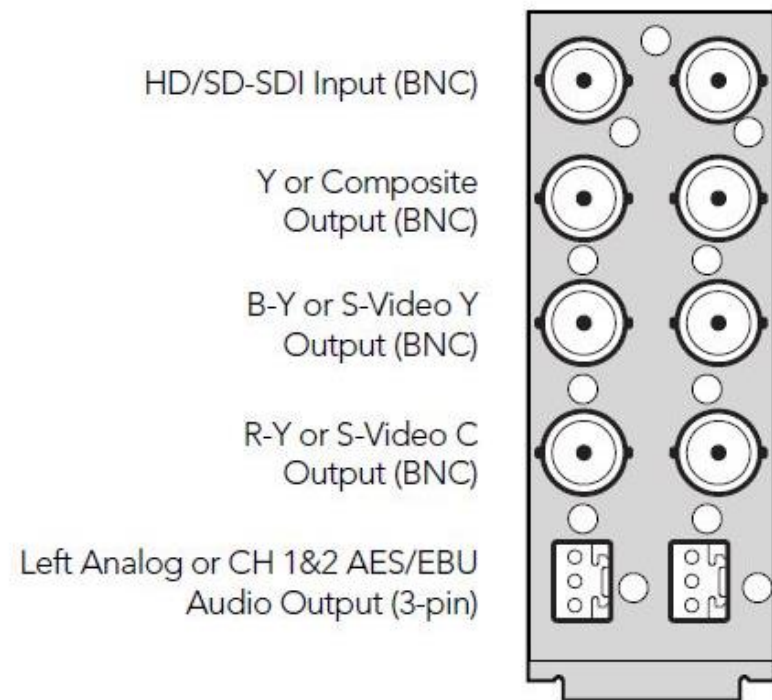

HD/SD-SDI Input (BNC)
 Y or Composite Output (BNC)
 B-Y or S-Video Y Output (BNC)
 R-Y or S-Video C Output (BNC)
 Left Analog or CH 1&2 AES/EBU Audio Output (3-pin)
 Alternate HD/SD-SDI Input (BNC)
 HD/SD-SDI Output (BNC)
 Right Analog Audio Output (3-pin)

Blackmagic OpenGear
 SDI to Analog rear module

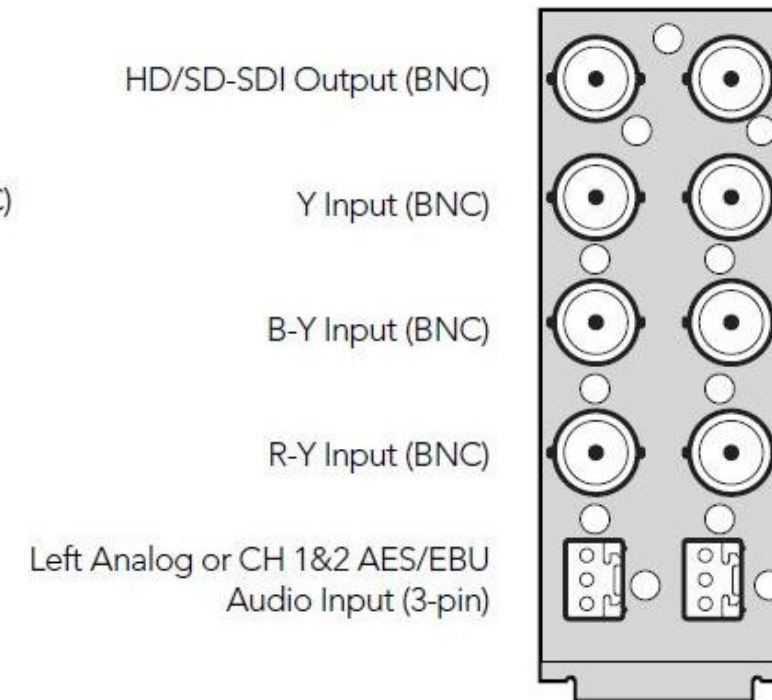

HD/SD-SDI Output (BNC)
 Y Input (BNC)
 B-Y Input (BNC)
 R-Y Input (BNC)
 Left Analog or CH 1&2 AES/EBU Audio Input (3-pin)
 HD/SD-SDI Output (BNC)
 Right Analog Audio Input (3-pin)

Blackmagic OpenGear
 Analog to SDI rear module

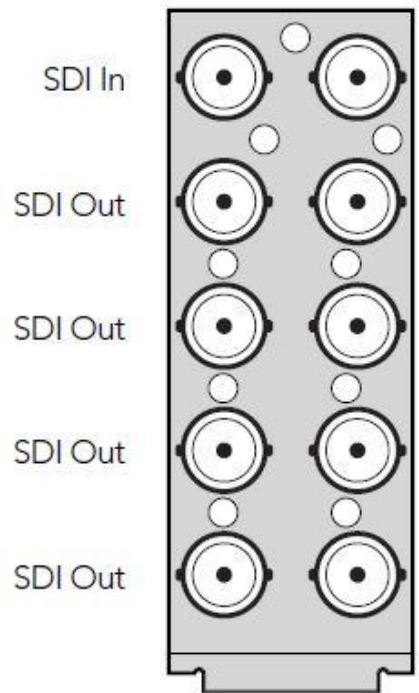

SDI In
 SDI Out
 SDI Out
 SDI Out
 SDI Out
 SDI Out

Blackmagic OpenGear
 SDI Distribution rear module

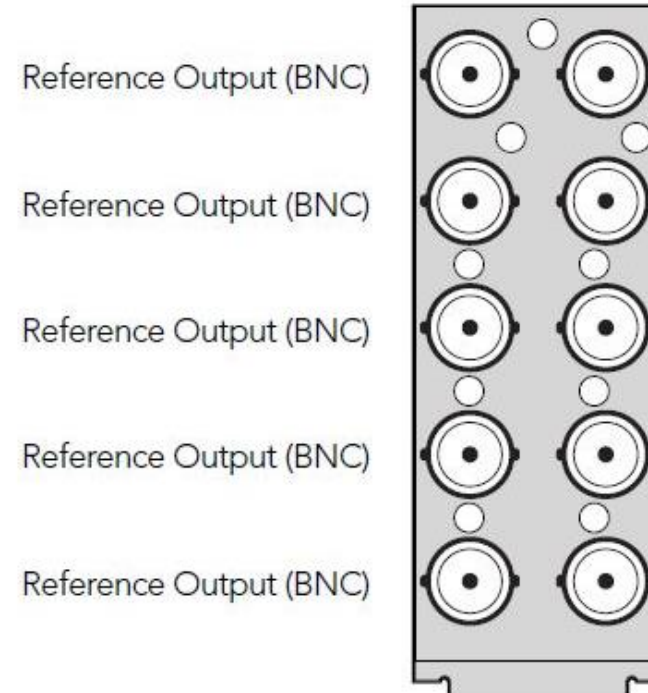

Reference Output (BNC)
 Reference Output (BNC)
 Reference Output (BNC)
 Reference Output (BNC)
 Reference Output (BNC)
 Reference Output (BNC)

Blackmagic OpenGear
 Sync Generator rear module

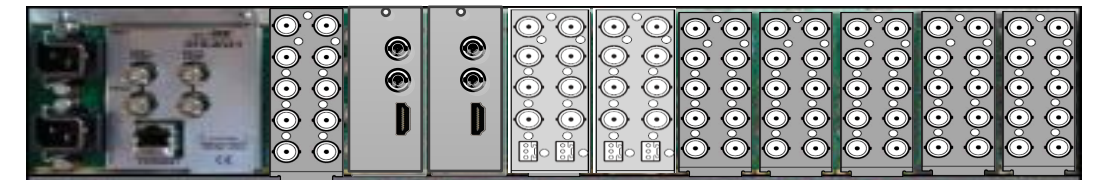

	2016 HCCS ALIEF FILMAKING		
	OPENGear CARDS – REAR PLATES		
L. BLANE HUHN	DATE MAY 17, 2016	DWG NO FILM – 2016 – 01	REV
HCC TV	SCALE NONE	11"x17"	SHEET 14 OF 27

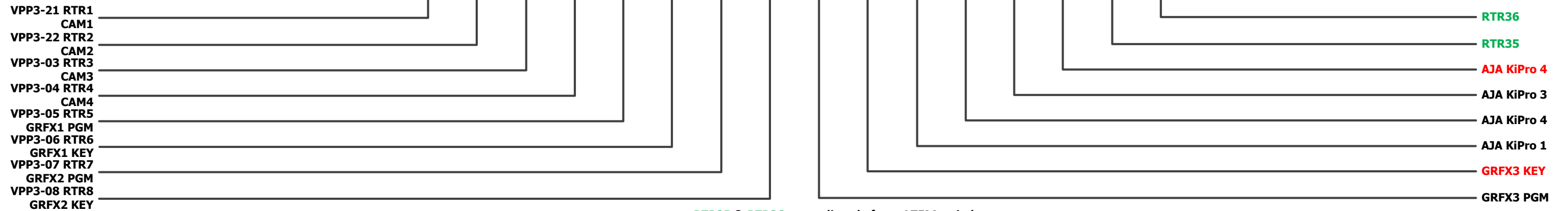
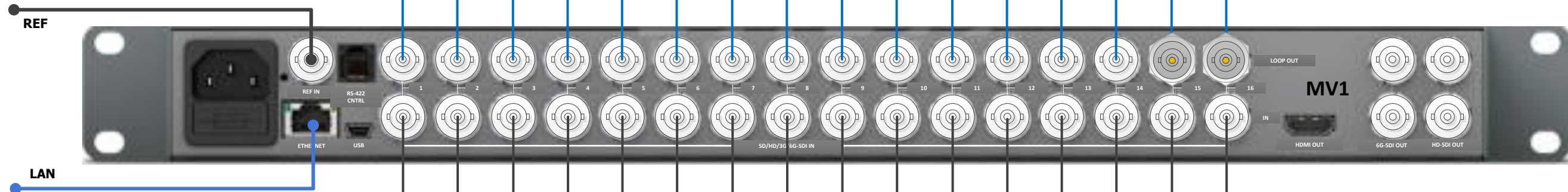
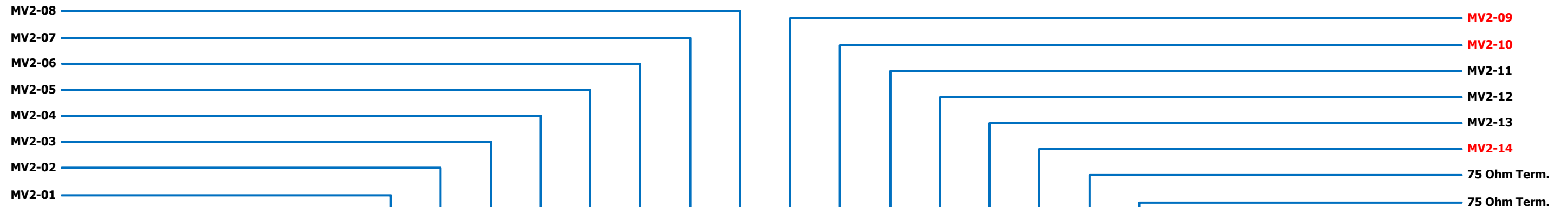

NOTE: This device does NOT have pass thru if power is NOT applied

RTR35 & RTR36 come directly from ATEM switcher outputs
 GRFX1 PGM/MV1-05 & GRFX1 KEY/MV1-06 via VDA1 and VDA2
 GRFX2 PGM/MV1-07 & GRFX2 KEY/MV1-08 via VDA3 and VDA4
 AJA4-1/MV1-14 & GRFX3 KEY/MV1-10 are not sourced yet. NC



	2016 HCCS ALIEF FILMAKING		
	MULTIVIEWER ONE		
L. BLANE HUHN	DATE MAR 24, 2016	DWG NO FILM - 2016 - 01	REV
HCC TV	SCALE NONE	11"x17"	SHEET 15 OF 27

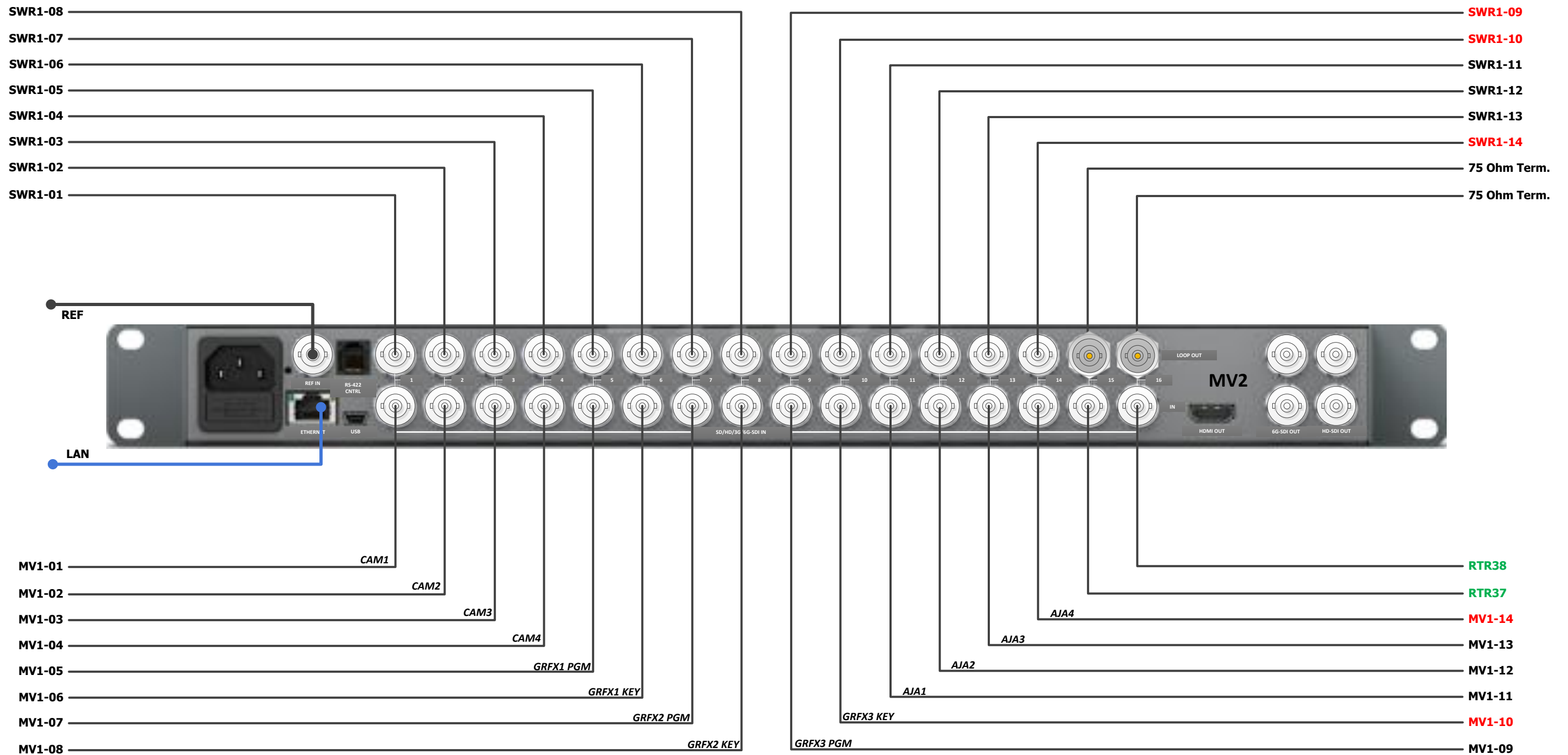

NOTE: This device does NOT have pass thru if power is NOT applied

RTR37 & RTR38 come directly from ATEM switcher outputs
 GRFX1 PGM/MV1-05 & GRFX1 KEY/MV1-06
 GRFX2 PGM/MV1-07 & GRFX2 KEY/MV1-08
 AJA4-1/MV1-14 & GRFX3 KEY/MV1-10 are not sourced yet. NC



	2016 HCCS ALIEF FILMAKING		
	MULTIEWER TWO		
L. BLANE HUHN	DATE MAR 24, 2016	DWG NO FILM - 2016 - 01	REV
HCC TV	SCALE NONE	11"x17"	SHEET 16 OF 27

SWITCHER INPUTS

- SWR1-14
- SWR1-13
- SWR1-12
- SWR1-11
- SWR1-10
- SWR1-09
- SWR1-08
- SWR1-07
- SWR1-06
- SWR1-05
- SWR1-04
- SWR1-03
- SWR1-02
- SWR1-01

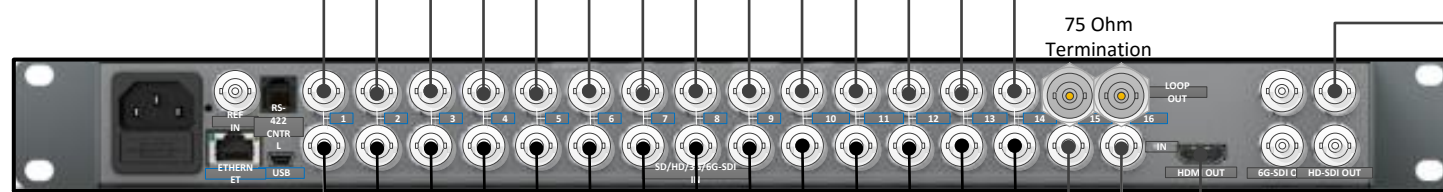

MULTVIEWER 2

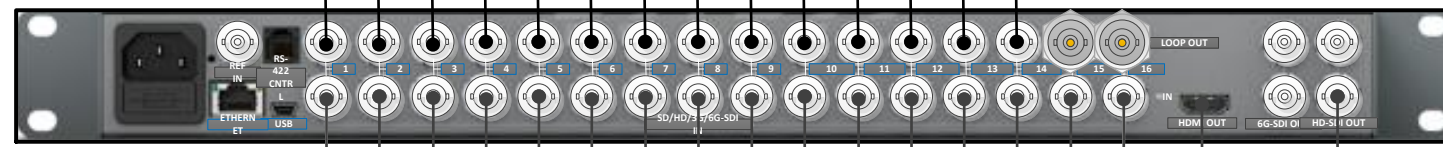

MULTVIEWER 1

ROUTER OUTPUTS

- RTR#01
- RTR#02
- RTR#03
- RTR#04
- RTR#05
- RTR#06
- RTR#07
- RTR#08
- RTR#09
- RTR#10
- RTR#11
- RTR#12
- RTR#13
- RTR#14
- RTR#15
- RTR#16
- RTR#17
- RTR#18

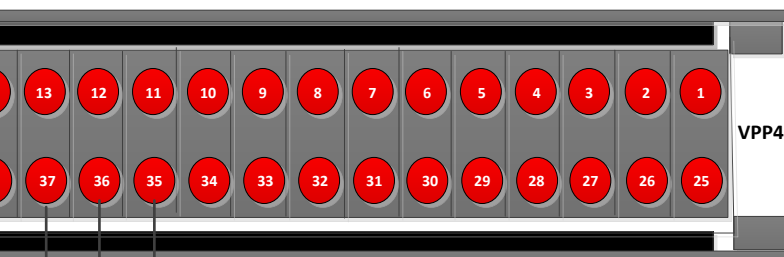
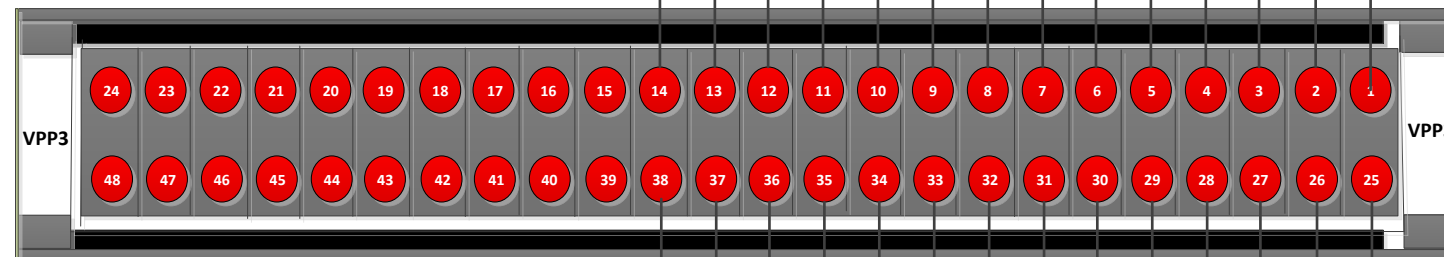

75 Ohm Termination

12X-10

ENGINEERING

12X-09
AUDIO BOOTH

RTR37

RTR38

RTR35

RTR36



2015 PRODUCTION CONTROL MONITOR WALL

MULTIEWER TOPOGRAPHY
(via router & patch panel)

L. BLANE HUHN

SIZE
17x22

DATE
APR 12, 2016

DWG NO
TOC - 2015 - MV13

REV

HCC TV

SCALE

NONE

TOC-RK#2

SHEET

17 OF 27

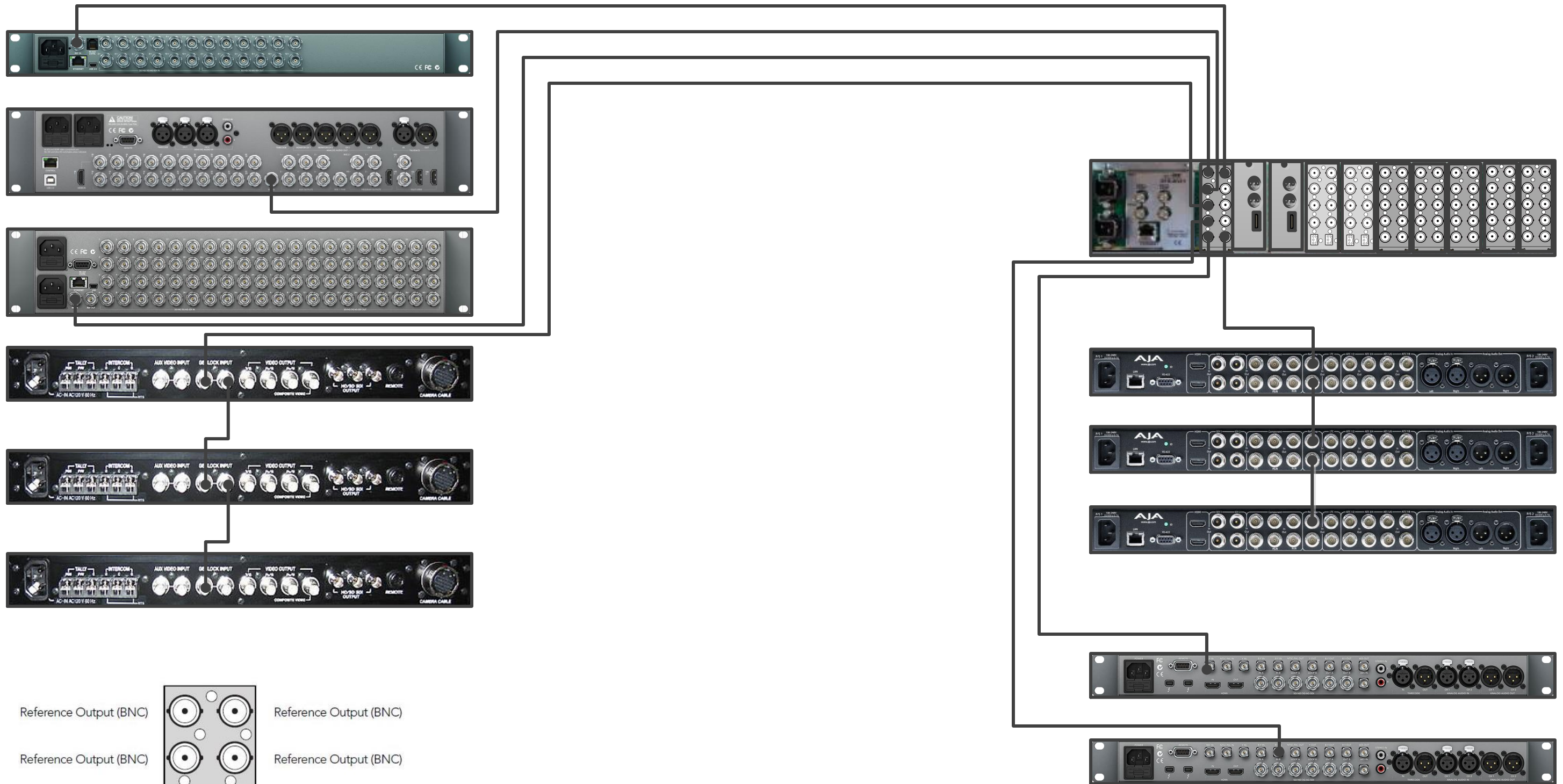

Reference Output (BNC)

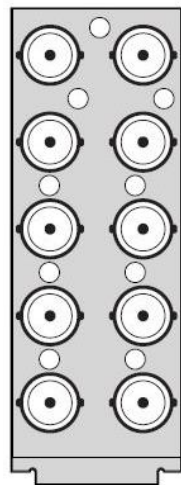

Reference Output (BNC)

Reference Output (BNC)

Reference Output (BNC)

Reference Output (BNC)

Reference Output (BNC)

Reference Output (BNC)

Reference Output (BNC)

Reference Output (BNC)

Reference Output (BNC)

Blackmagic OpenGear
Sync Generator rear module

	2016 HCCS ALIEF FILMAKING		
	MASTER SYNCHRONIZER & REFERENCE BLACK		
L. BLANE HUHN	DATE APR 13, 2016	DWG NO FILM - 2016 - 01	REV
HCC TV	SCALE NONE	11"x17"	SHEET 18 OF 27

VPP1-01=>VPP1-24 VPP1-25=>VPP1-48

VPP3-01=>VPP3-24 VPP3-25=>VPP3-48

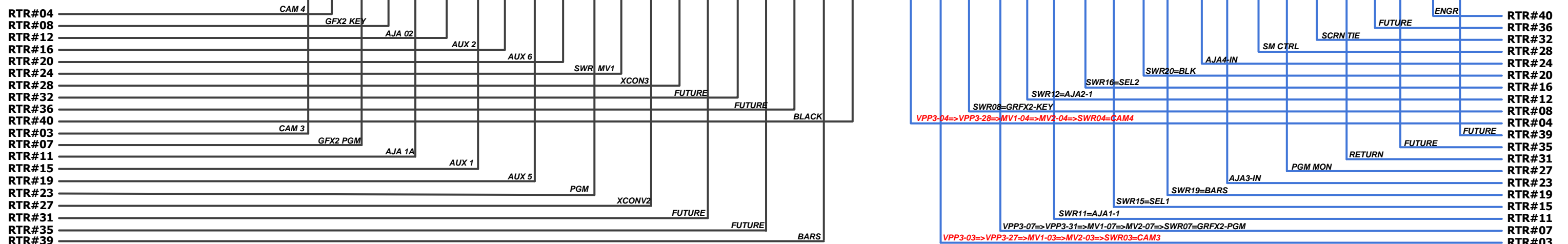
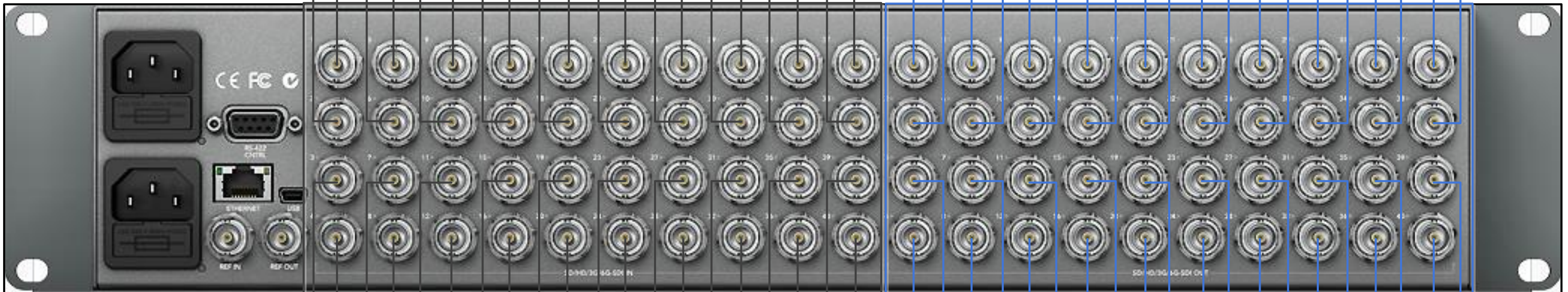
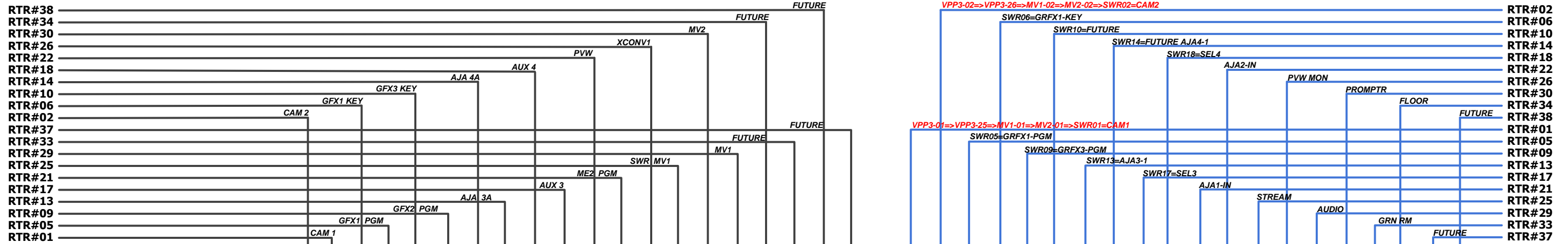

NOTE: ALL router INPUTS and OUTPUTS are sent through video patch panels on a one-to-one numeric correlation. The first 40 router INPUTS are on the normal loop side of VPP-1 and VPP-2. The first 20 router OUTPUTS are on the normal loop side of VPP-3 and VPP-4 into the ATEM 2ME switcher INPUTS 1-20 via MV1 & MV2. Also, RTR15 & RTR16 OUTPUTS bypass both MVI & MV2

	2016 HCCS ALIEF FILMAKING		
	ROUTER I/O CONNECTIONS		
L. BLANE HUHN	DATE Aug 10, 2016	DWG NO FILM - 2016 - 01	REV
HCC TV	SCALE NONE	11"x17"	SHEET 19 OF 27

Patch Bay #1

Router Input 1	0	1	0	Camera 1 Output A
Router Input 2	0	2	0	Camera 2 Output A
Router Input 3	0	3	0	Camera 3 Output A
Router Input 4	0	4	0	Camera 4 Output A (open)
Router Input 5	0	5	0	Graphics Station1 Main Output (Blackmagic Ultrastudio)
Router Input 6	0	6	0	Graphics Station1 Key Output (Blackmagic Ultrastudio)
Router Input 7	0	7	0	Graphics Station2 Main Output (Blackmagic Ultrastudio)
Router Input 8	0	8	0	Graphics Station2 Key Output (Blackmagic Ultrastudio)
Router Input 9	0	9	0	Graphics Station3 Main Output (Blackmagic Ultrastudio)
Router Input 10	0	10	0	Graphics Station3 Key Output (Blackmagic Ultrastudio)
Router Input 11	0	11	0	KiPro #1 Output A
Router Input 12	0	12	0	KiPro #2 Output A
Router Input 13	0	13	0	KiPro #3 Output A
Router Input 14	0	14	0	KiPro #4 Output A
Router Input 15	0	15	0	Production Switcher Aux A Out
Router Input 16	0	16	0	Production Switcher Aux B Out
Router Input 17	0	17	0	Production Switcher Aux C Out
Router Input 18	0	18	0	Production Switcher Aux D Out
Router Input 19	0	19	0	Production Switcher Aux E Out
Router Input 20	0	20	0	Production Switcher Aux F Out

Patch Bay #2

Router Input 21	0	1	0	Production Switcher M/E 1 Preview out
Router Input 22	0	2	0	Production Switcher Preview Out
Router Input 23	0	3	0	Production Switcher Program Out
Router Input 24	0	4	0	Production Switcher Multiview #1 Out
Router Input 25	0	5	0	Production Switcher Multiview #2 Out
Router Input 26	0	6	0	HDMI to HD-SDI converter 1 Out (open rack)
Router Input 27	0	7	0	HDMI to HD-SDI converter 2 Out (open rack)
Router Input 28	0	8	0	Analog to SDI converter Out (open rack)
Router Input 29	0	9	0	Multiview 16 #1 (engineering multiview) out
Router Input 30	0	10	0	Multiview 16 #2 (Audio booth) out
Router Input 31	0	11	0	
Router Input 32	0	12	0	
Router Input 33	0	13	0	
Router Input 34	0	14	0	
Router Input 35	0	15	0	
Router Input 36	0	16	0	
Router Input 37	0	17	0	
Router Input 38	0	18	0	
Router Input 39	0	19	0	Test Signal Generator Out
Router Input 40	0	20	0	Sync/Video Black

Patch Bay #3

Switcher Input 01	0	1	0	Router Output 1
Switcher Input 02	0	2	0	Router Output 2
Switcher Input 03	0	3	0	Router Output 3
Switcher Input 04	0	4	0	Router Output 4
Switcher Input 05	0	5	0	Router Output 5
Switcher Input 06	0	6	0	Router Output 6
Switcher Input 07	0	7	0	Router Output 7
Switcher Input 08	0	8	0	Router Output 8
Switcher Input 09	0	9	0	Router Output 9
Switcher Input 10	0	10	0	Router Output 10
Switcher Input 11	0	11	0	Router Output 11
Switcher Input 12	0	12	0	Router Output 12
Switcher Input 13	0	13	0	Router Output 13
Switcher Input 14	0	14	0	Router Output 14
Switcher Input 15	0	15	0	Router Output 15
Switcher Input 16	0	16	0	Router Output 16
Switcher Input 17	0	17	0	Router Output 17
Switcher Input 18	0	18	0	Router Output 18
Switcher Input 19	0	19	0	Router Output 19
Switcher Input 20	0	20	0	Router Output 20



CANARE 50DV VIDEO PATCH PANELS

VPP5, VPP6 & VPP7 are planned in the design though no source/designations have been assigned

	2016 HCCS ALIEF FILMAKING		
	VIDEO PATCH PANEL MATRIX VPP1-3		
L. BLANE HUHN	DATE MAY 24, 2016	DWG NO FILM - 2016 - 01	REV
HCC TV	SCALE NONE	11"x17"	SHEET 20 OF 27

Patch Bay #4				Patch Bay #5				Patch Bay #6			
KiPro #1 Input	0	1	0	Router Output 21	0	1	0		0	1	0
KiPro #2 Input	0	2	0	Router Output 22	0	2	0		0	2	0
KiPro #3 Input	0	3	0	Router Output 23	0	3	0		0	3	0
KiPro #4 Input (open cable)	0	4	0	Router Output 24	0	4	0		0	4	0
Video Streaming Encoder	0	5	0	Router Output 25	0	5	0		0	5	0
Control Room Preview Monitor	0	6	0	Router Output 26	0	6	0		0	6	0
Control Room Program Monitor	0	7	0	Router Output 27	0	7	0		0	7	0
Small Control Room Monitors??	0	8	0	Router Output 28	0	8	0		0	8	0
Audio Control Room Monitor	0	9	0	Router Output 29	0	9	0		0	9	0
Teleprompter Input	0	10	0	Router Output 30	0	10	0		0	10	0
Camera Return Video	0	11	0	Router Output 31	0	11	0		0	11	0
Screening Theater Tie Line	0	12	0	Router Output 32	0	12	0		0	12	0
Green Room Monitor	0	13	0	Router Output 33	0	13	0		0	13	0
Floor Monitor	0	14	0	Router Output 34	0	14	0		0	14	0
MV16-1-15 Audio Booth	0	15	0	Router Output 35	0	15	0		0	15	0
MV16-16 Audio Booth	0	16	0	Router Output 36	0	16	0		0	16	0
MV16-2-15 ENGR Racks	0	17	0	Router Output 37	0	17	0		0	17	0
MV16-2-16 ENGR Racks	0	18	0	Router Output 38	0	18	0		0	18	0
TBD	0	19	0	Router Output 39	0	19	0		0	19	0



CANARE 50DV VIDEO PATCH PANELS

VPP5, VPP6 & VPP7 are planned in the design though no source/designations have been assigned

	2016 HCCS ALIEF FILMAKING		
	VIDEO PATCH PANEL MATRIX VPP4-6		
L. BLANE HUHN	DATE MAY 24, 2016	DWG NO FILM - 2016 - 01	REV
HCC TV	SCALE NONE	11"x17"	SHEET 21 OF 27

SOURCES SIGNALS DIRECT FROM DEVICES

AUX F VPP1-20 AUX E VPP1-19 AUX D VPP1-18 AUX C VPP1-17 AUX B VPP1-16 AUX A VPP1-15 KiPro4 VPP1-14 KiPro3 VPP1-13 KiPro2 VPP1-12 KiPro1 VPP1-11 GFX3 KEY VPP1-10 GFX3 PGM VPP1-09 GFX2 KEY VPP1-08 GFX2 PGM VPP1-07 GFX1 KEY VPP1-06 GFX1 PGM VPP1-05 CAM4 VPP1-04 CAM3 VPP1-03 CAM2 VPP1-02 CAM1 VPP1-01

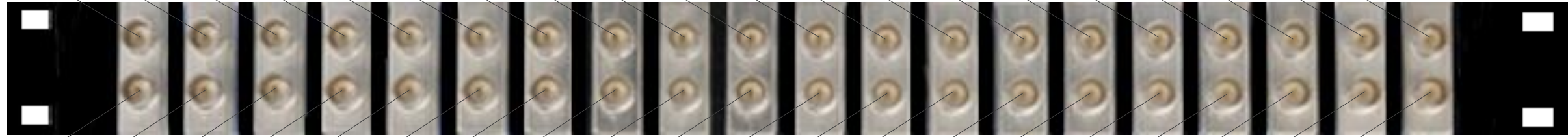

VPP1-40 RTR20 VPP1-39 RTR19 VPP1-38 RTR18 VPP1-37 RTR17 VPP1-36 RTR16 VPP1-35 RTR15 VPP1-34 RTR14 VPP1-33 RTR13 VPP1-32 RTR12 VPP1-31 RTR11 VPP1-30 RTR10 VPP1-29 RTR9 VPP1-28 RTR8 VPP1-27 RTR7 VPP1-26 RTR6 VPP1-25 RTR5 VPP1-24 RTR4 VPP1-23 RTR3 VPP1-22 RTR2 VPP1-21 RTR1

BLK VPP2-20 BARS VPP2-19 TBD VPP2-18 TBD VPP2-17 TBD VPP2-16 TBD VPP2-15 TBD VPP2-14 TBD VPP2-13 TBD VPP2-12 TBD VPP2-11 MV16-2 VPP2-10 MV16-1 VPP2-09 AtoD VPP2-08 HDMix2 VPP2-07 HDMix1 VPP2-06 MV-2 VPP2-05 MV-1 VPP2-04 PGM VPP2-03 PVW VPP2-02 M/E1 PVW VPP2-01

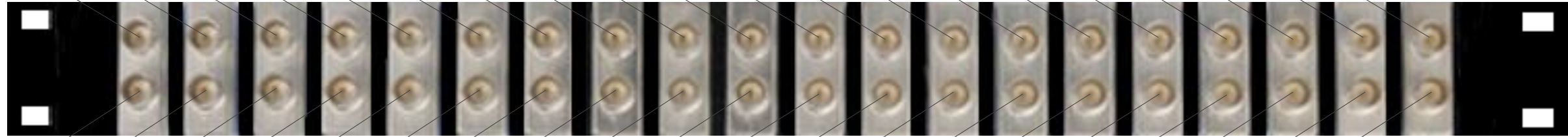

VPP2-40 RTR40 VPP2-39 RTR39 VPP2-38 RTR38 VPP2-37 RTR37 VPP2-36 RTR36 VPP2-35 R35RT VPP2-34 RTR34 VPP2-33 RTR33 VPP2-32 RTR32 VPP2-31 RTR31 VPP1-30 RTR30 VPP2-29 RTR29 VPP2-28 RTR28 VPP2-27 RTR27 VPP1-26 RTR26 VPP2-25 RTR25 VPP1-24 RTR24 VPP2-23 RTR23 VPP1-22 RTR22 VPP2-21 RTR21

RTR20 VPP3-20 RTR19 VPP3-19 RTR18 VPP3-18 RTR17 VPP3-17 RTR16 VPP3-16 RTR15 VPP3-15 RTR14 VPP3-14 RTR13 VPP3-13 RTR12 VPP3-12 RTR11 VPP3-11 RTR10 VPP3-10 RTR9 VPP3-09 RTR8 VPP3-08 RTR7 VPP3-07 RTR6 VPP3-06 RTR5 VPP3-05 RTR4 VPP3-04 RTR3 VPP3-03 RTR2 VPP3-02 RTR1 VPP3-01

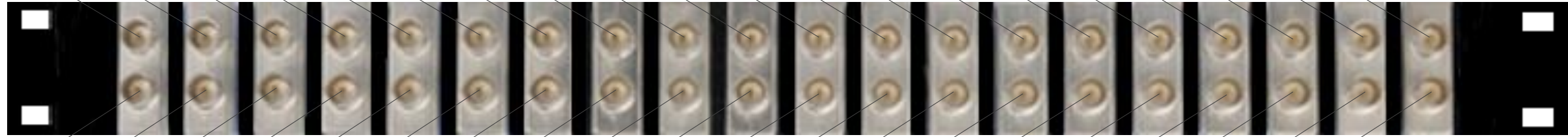

VPP3-40 DIRECT SWR20 VPP3-39 DIRECT SWR19 VPP3-38 DIRECT SWR18 VPP3-37 DIRECT SWR17 VPP3-36 DIRECT SWR16 VPP3-35 DIRECT SWR15 VPP3-34 MV16-1-14 SWR14 VPP3-33 MV16-1-13 SWR13 VPP3-32 MV16-1-12 SWR12 VPP3-31 MV16-1-11 SWR11 VPP3-30 MV16-1-10 SWR10 VPP3-29 MV16-1-9 SWR9 VPP3-28 MV16-1-8 SWR8 VPP3-27 MV16-1-7 SWR7 VPP3-26 MV16-1-6 SWR6 VPP3-25 MV16-1-5 SWR5 VPP3-24 MV16-1-4 SWR4 VPP3-23 MV16-1-3 SWR3 VPP3-22 MV16-1-2 SWR2 VPP3-21 MV16-1-1 SWR1



	2016 HCCS ALIEF FILMAKING		
	VIDEO PATCH PANELS 1-3 (rear view)		
L. BLANE HUHN	DATE MAY 13, 2016	DWG NO FILM - 2016 - 01	REV
HCC TV	SCALE NONE	11"x17"	SHEET 22 OF 27

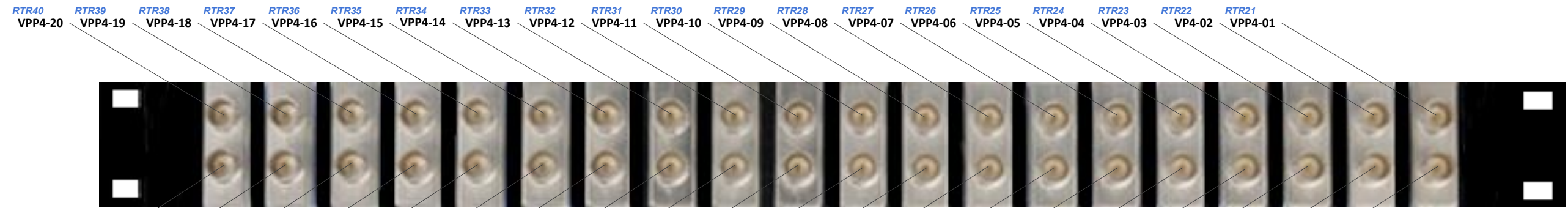

VPP4-40 TBD VPP4-39 TBD VPP4-38 AUX D MV16-2-15 VPP4-37 AUX C MV16-2-15 VPP4-36 AUX B MV16-1-16 VPP4-35 AUX A MV16-1-15 VPP4-34 FLR MON VPP4-33 GRN MON VPP4-32 SCRNM RM VPP4-31 CAM RET VPP4-30 PROMPT VPP4-29 AUD MON VPP4-28 SMCRR MON VPP4-27 PGM MON VPP4-26 PVW MON VPP4-25 STR ENC VPP4-24 KiPro4 VPP4-23 KiPro3 VPP4-22 KiPro2 VPP4-21 KiPro1

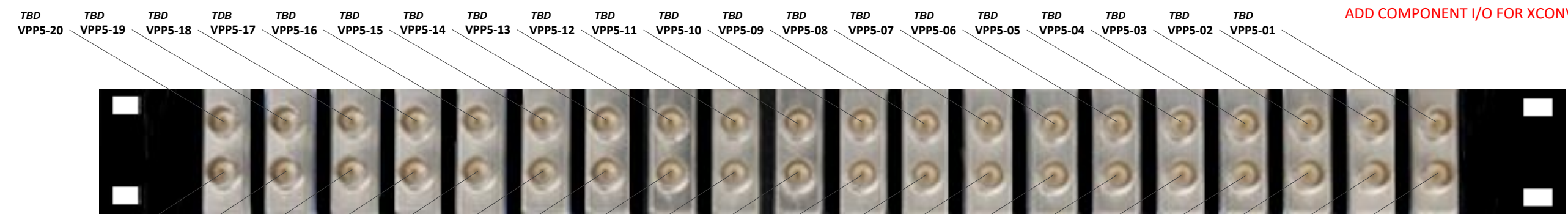

VPP5-40 TBD VPP5-39 TBD VPP5-38 TBD VPP5-37 TBD VPP5-36 TBD VPP5-35 TBD VPP5-34 TBD VPP5-33 TBD VPP5-32 TBD VPP5-31 TBD VPP5-30 TBD VPP5-29 TBD VPP5-28 TBD VPP5-27 TBD VPP5-26 TBD VPP5-25 TBD VPP5-24 TBD VPP5-23 TBD VPP5-22 TBD VPP5-21 TBD

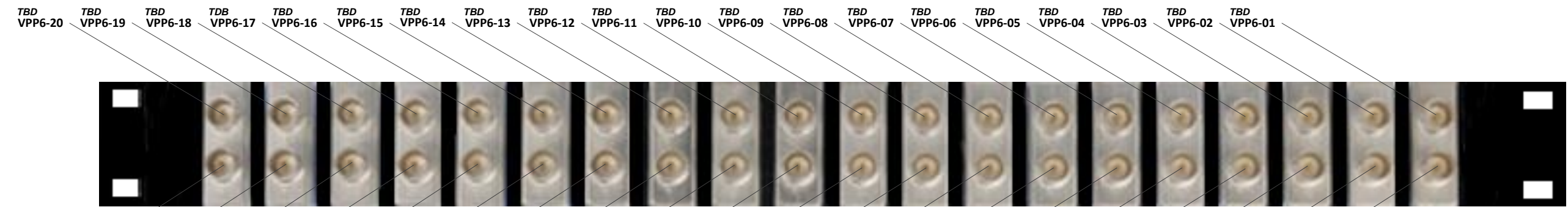

VPP6-40 TBD VPP6-39 TBD VPP6-38 TBD VPP6-37 TBD VPP6-36 TBD VPP6-35 TBD VPP6-34 TBD VPP6-33 TBD VPP6-32 TBD VPP6-31 TBD VPP6-30 TBD VPP6-29 TBD VPP6-28 TBD VPP6-27 TBD VPP6-26 TBD VPP6-25 TBD VPP6-24 TBD VPP6-23 TBD VPP6-22 TBD VPP6-21 TBD

ADD COMPONENT I/O FOR XCONV & BETA DECKS



	2016 HCCS ALIEF FILMAKING		
	VIDEO PATCH PANELS 4-6 (rear view)		
L. BLANE HUHN	DATE MAY 13, 2016	DWG NO FILM - 2016 - 01	REV
HCC TV	SCALE NONE	11"x17"	SHEET 23 OF 27



To Audio Distribution Amp



XLR Audio Wire Option

BNC "T"

Coaxial Cable Option

Typical connections for all clock displays



ESE/SMPTE/EBU
GROUND
ASCII
GROUND



	2016 HCCS ALIEF FILMMAKING		
	ESE MASTER CLOCK & TIME CODE GENERATOR		
L. BLANE HUHN	DATE APR 25, 2016	DWG NO FILM - 2016 - 01	REV
HCC TV	SCALE NONE	11"x17"	SHEET 24 OF 27

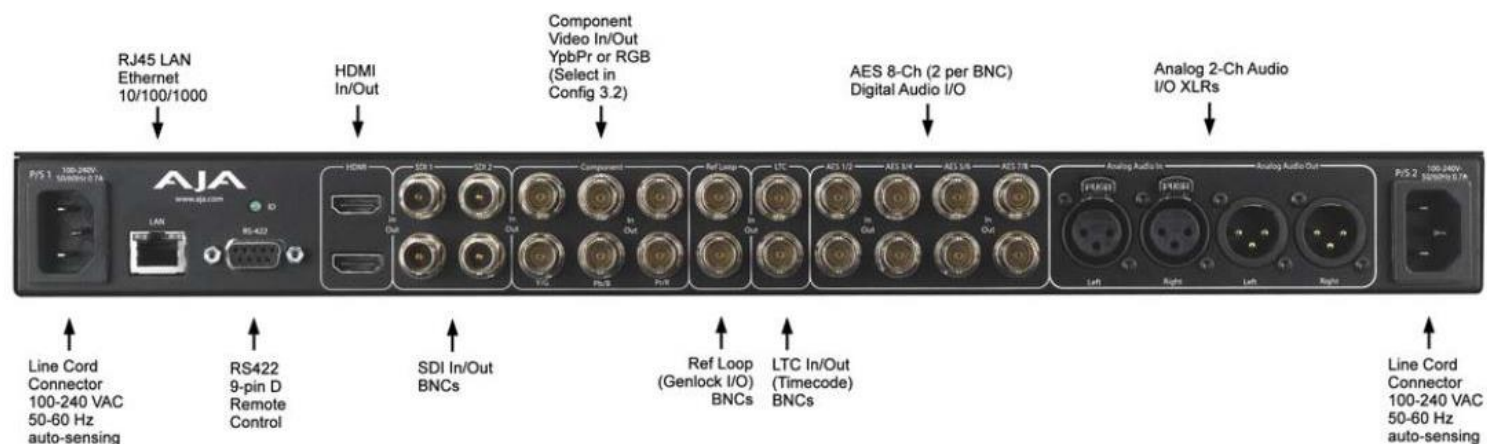
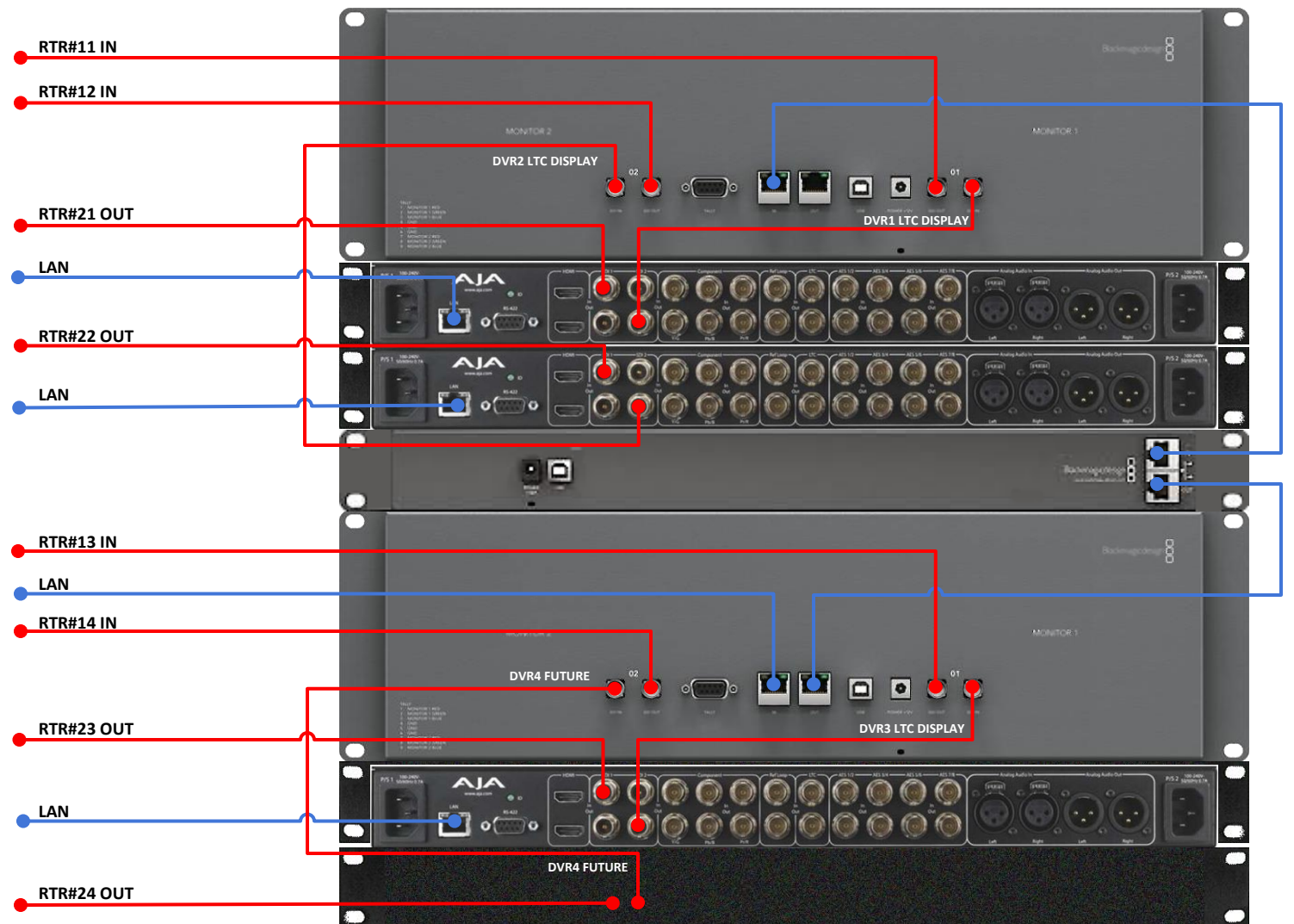
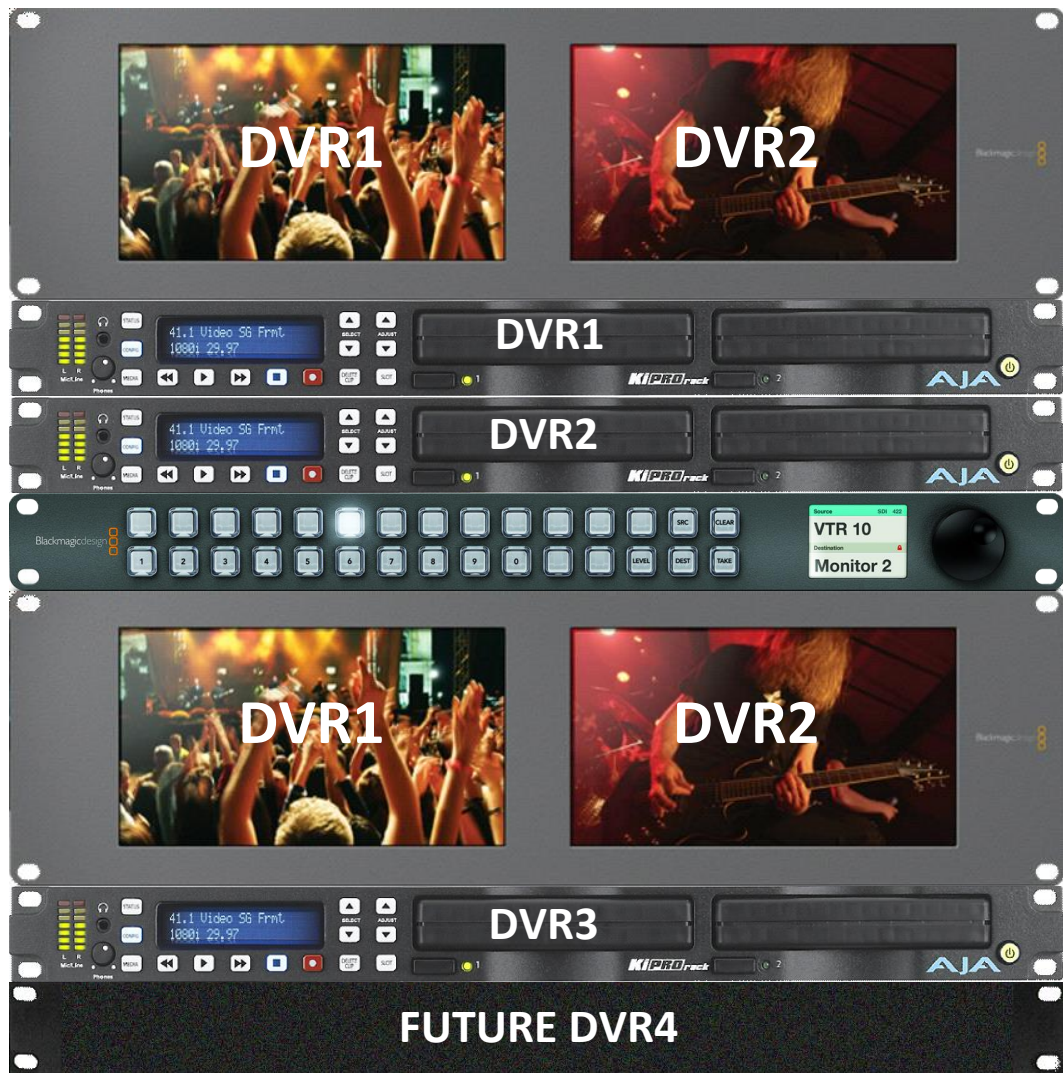

	2016 HCCS ALIEF FILMAKING		
	VIDEO CONTROL RECORD & PLAYBACK		
AJA KiPro			
L. BLANE HUHN HCC TV	DATE	DWG NO	REV
	MAY 17, 2016	FILM - 2016 - 01	
SCALE	NONE	11"x17"	SHEET 25 OF 27



This device will serve in a semi-permanent location as the TSG for BARS into the router as RTR39 at VPP2-19

F-Stop Display Mode (relative exposure)

You can easily and accurately measure exposure values directly from the camera signal. This feature is fundamentally different from conventional spot measurement. It is especially useful for making lighting arrangements when filming.

F-stop display based on the active measured position and the 18% reference set

Active Measured

Reference position

F-stop value display based on the reference position and the 18% reference set

F-stop value display based on the difference between the reference position and the active measured position

CINEZONE

You can achieve a flawless picture when filming. This feature is especially useful for making lighting arrangements. You can easily and accurately confirm dark areas with approximately 5% luminance, areas with approximately 45% of the luminance of the film subject, and bright areas with luminances of 80% or more.

CINEZONE Display



UPPER%	LOWER%
99.0	5.0

Normal Display



RGB 255 Display

R: 219 G: 83 B: 89

RGB % Display Mode

R: 86.2% G: 32.9% B: 35.3%

LUMINANCE % Display Mode

44.4%

	2016 HCCS ALIEF FILMAKING		
	Multi-SDI Waveform Monitor (Leader LV-5333)		
L. BLANE HUHN	DATE FEB 17, 2016	DWG NO FILM - 2016 - 01	REV
HCC TV	SCALE NONE	11"x17"	SHEET 26 OF 27

VIDEO CONTROL ROOM/AUDIO BOOTH EQUIPMENT POWER CONSUMPT

DEVICE	RATED -PEAK AC POWER RATING (W)	PEAK CURRENT (A)
AJA Ki Pro Rackmount Video Recorder (3)	120	1.09
APPLE 27" Imac (3)	1320	12.00
BEHRINGER X-DANTE 32 Ch Dante Exp Card	0	0.00
BEHRINGER TRUTH B2031A Pwr Speakers(2)	440	4.00
BLACKMAGIC Video Hub 40x40 6G-SDI (1)	0	0.00
BLACKMAGIC Video Hub Master Control (3)	0	0.00
BLACKMAGIC OG3 CARD FRAME (1)	450	4.09
BLACK MAGIC Ultra Studio 4K (estimate)(2)	200	1.82
CLEARCOM SB-704 Main Station	60	0.55
CLEARCOM RM-702 (8)	0.88	0.01
CLEARCOM IF 4W4 4CH Camera Interface	0	0.00
CLEARCOM KB-702 Wall Station(2)	0	0.00
CLEARCOM FL-7 Call Signal Flasher (2)	0	0.00
ESE ES-188 NTP Master Clock/TC Generator	15	0.14
ESE 2.3" 6 Digit Timecode Reader (6)	60	0.55
JOECO BBR-DANTE Audio Recorder	20	0.18
JVC GY-HM890CHU ProHD ENG Camera	0	0.00
JVC RM-HP790DU HD/SD CCU (3)	240	2.18
IKAN 17" Rod Based Teleprompter Kit (3)**	150	1.36
KLARK-TEKNIC MIDAS M32 Digital Mixer	70	0.64
MACKIE SRM550 1600W Pwr Speakers(2)*	350	3.18
SAMSUNG UN40HU6950FXZA 40" UHD 4K TV	130	1.18
SHARP AQUOS LC-70UD27U 70" 4K LED TV	300	2.73
SONNET ECHO Docking Unit ThunnderBolt(3)	0	0.00
Sony X850B 48" Ultra HD TV Monitors (3)	750	6.82
Sony LMD-A220 22" LCD Monitors (2)	94	0.85
	4769.88	43.36
	based on 110Vac	

	2016 HCCS ALIEF FILMMAKING		
	POWER CONSUMPTION VALUES		
L. BLANE HUHN	DATE FEB 22, 2016	DWG NO FILM - 2016 - 01	REV
HCC TV	SCALE NONE	11"x17"	SHEET 27 OF 27